

SteriLUX®

0.2 µm VMH-grade 50 mm Filter (CB2 Model)

Description

SteriLUX® is a hydrophilic PVDF membrane filter with high flow rates, high throughputs, low protein binding properties and broad chemical compatibility. It is recommended for sterilizing filtration and bioburden reduction of pharmaceutical preparations, active ingredients, biopharmaceuticals, parenterals, vaccines, biologicals including dilute protein solutions, cell and tissue culture media, media additives, ophthalmic and other dilute preservative solutions, UPW, chemicals, alcohols and sanitizing agents.

Materials of Construction

All components of the encapsulated discs are animal component free (ACF). These materials are listed for food contact use in the Code of Federal Regulations (CFR), Title 21, as below:

Membrane:	Polyvinylidene fluoride	CFR Title 21, 177.2510
Downstream support:	Polypropylene	CFR Title 21, 177.1520
Capsule housing:	Polypropylene	CFR Title 21, 177.1520
Sealing method:	Thermal bonding	

Pore Size 0.2 µm

EFA 19.6 cm²

Bacterial Retention >10⁷ cfu/cm² retention of *Brevundimonas diminuta* per ASTM F838

Minimum Bubble Point
50 psi (3.4 bar), water
18 psi (1.24 bar), 60% IPA/40% water
17 psi (1.17 bar), 70% IPA/30% water

Operating Characteristics

Operating temperature range: 32 °F to 100 °F (0 °C to 38 °C)
Maximum operating pressure: 80 psig (5.5 bar @ 38 °C)

Sterilization

Autoclave: 121 °C to 135 °C (15 to 30 psi, 1 to 2 bar), 30 to 60 minutes, ≥ 3 cycles.
Gamma irradiation: 25 to 40 kGy once. Do not autoclave irradiated capsules.
Capsules must not be in-line steam sterilized.

Biological Safety

SteriLUX® filters meet the requirements as specified in the current USP <88> Class VI plastics, physicochemical, oxidizable substances, and USP <87> cytotoxicity tests. No adhesives, binders or surfactants are used in the construction of the filters. Filters comply with European Commission Regulation No 10/2011. Capsules are TSE/BSE/ animal component free (ACF).

Quality Assurance

SteriLUX® filters comply with the Food and Drug Administration Code of Federal Regulations, Title 21, Parts 210 and 211. Product is manufactured and packaged in a cleanroom facility that, through voluntary compliance, meets or exceeds FDA Good Manufacturing Practice Standards. To ensure product reliability, Meissner's Quality Assurance staff continually audits the manufacturing process for conformance to its Quality Management System. Each SteriLUX® filter is clearly marked with filter type and lot number.

Ordering Guide

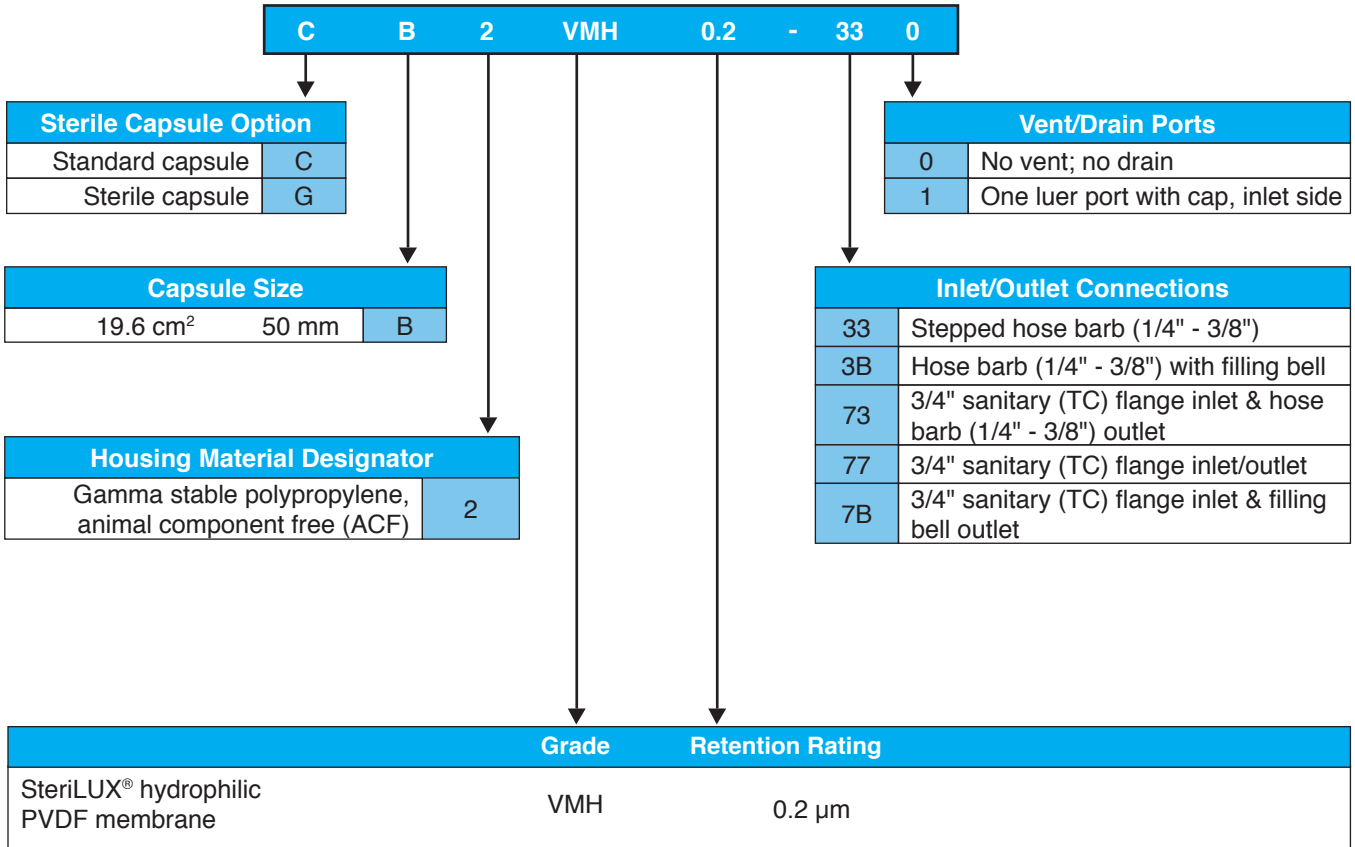

Additional information about this filter product is available in the SteriLUX[®] Green Docs document at www.meissner.com/green-docs.

SteriLUX[®] is a registered trademark of Meissner Filtration Products.
 © 2017 Meissner Filtration Products, Inc. All rights reserved.